

LABC Registered Construction Details Masonry

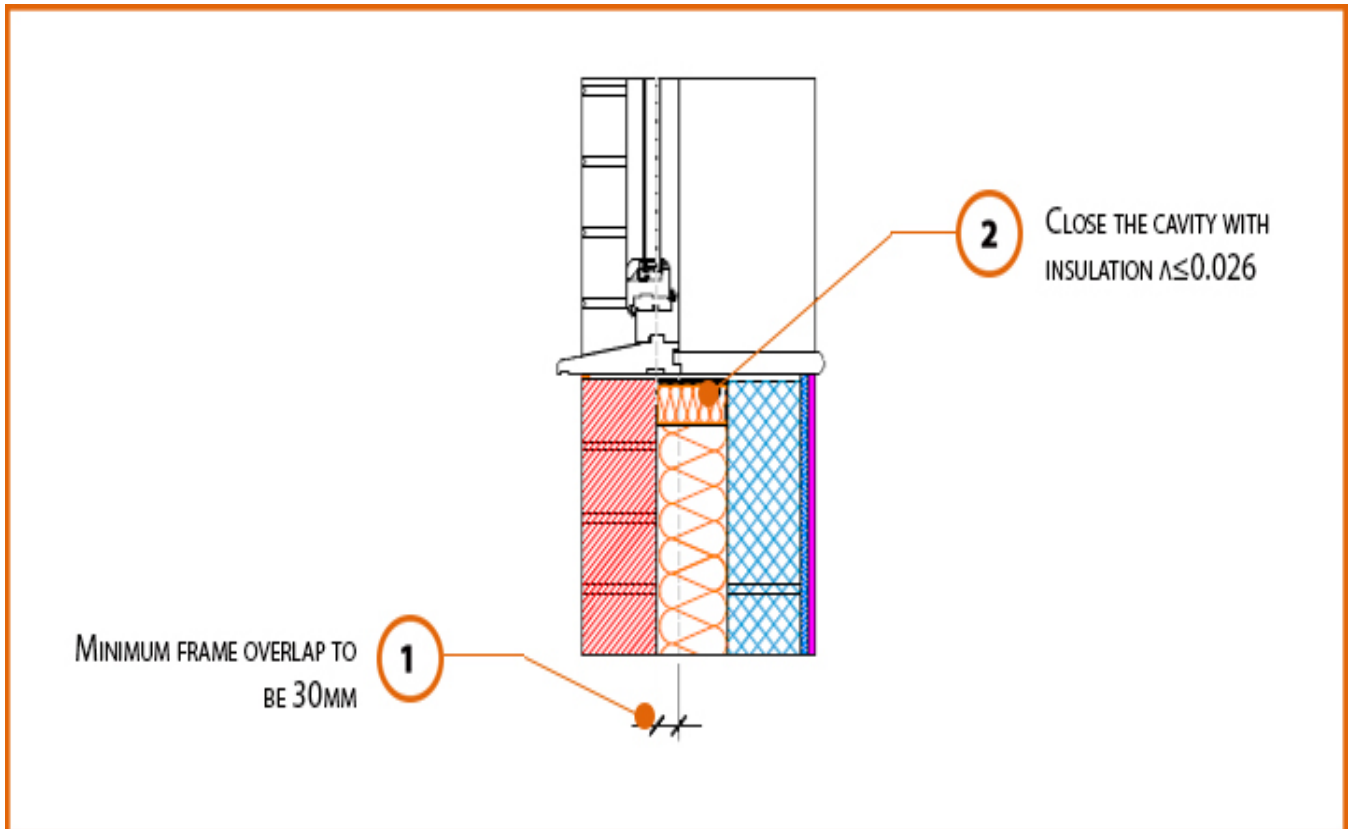

Registration Number: E3MCFF2



Build Up

External Masonry Cavity Wall

Masonry Outer Leaf ($\lambda = 0.77$)

Lightweight Concrete Block $\lambda \leq 0.60$ W/mK

Full Fill Insulation

Window Sill



Calculated ψ -values

Cavity Insulation	Inner leaf blockwork
	Lightweight Concrete Block $\lambda \leq 0.60$ W/mK
	ψ -value W/mK
100mm $\lambda=0.037$	0.013
100mm $\lambda=0.032$	0.015
150mm $\lambda=0.037$	0.019
150mm $\lambda=0.032$	0.020

Points to Watch

- Cavity should be closed with a proprietary cavity closer or block of insulation
- Ensure the cavity closer is in contact with the insulation within the cavity and the window / door frame.
- Ensure cavities are kept clean of mortar snots and other debris during construction
- A flexible sealant should be applied to the junction between the plaster/ plasterboard, sill board and window frame member
- Sealant should be added to the front and back of the sill board
- Ensure that the damp proof course is correctly positioned.